

		Form B
Pilote ID	France Espoirs inconnu	Vol N°

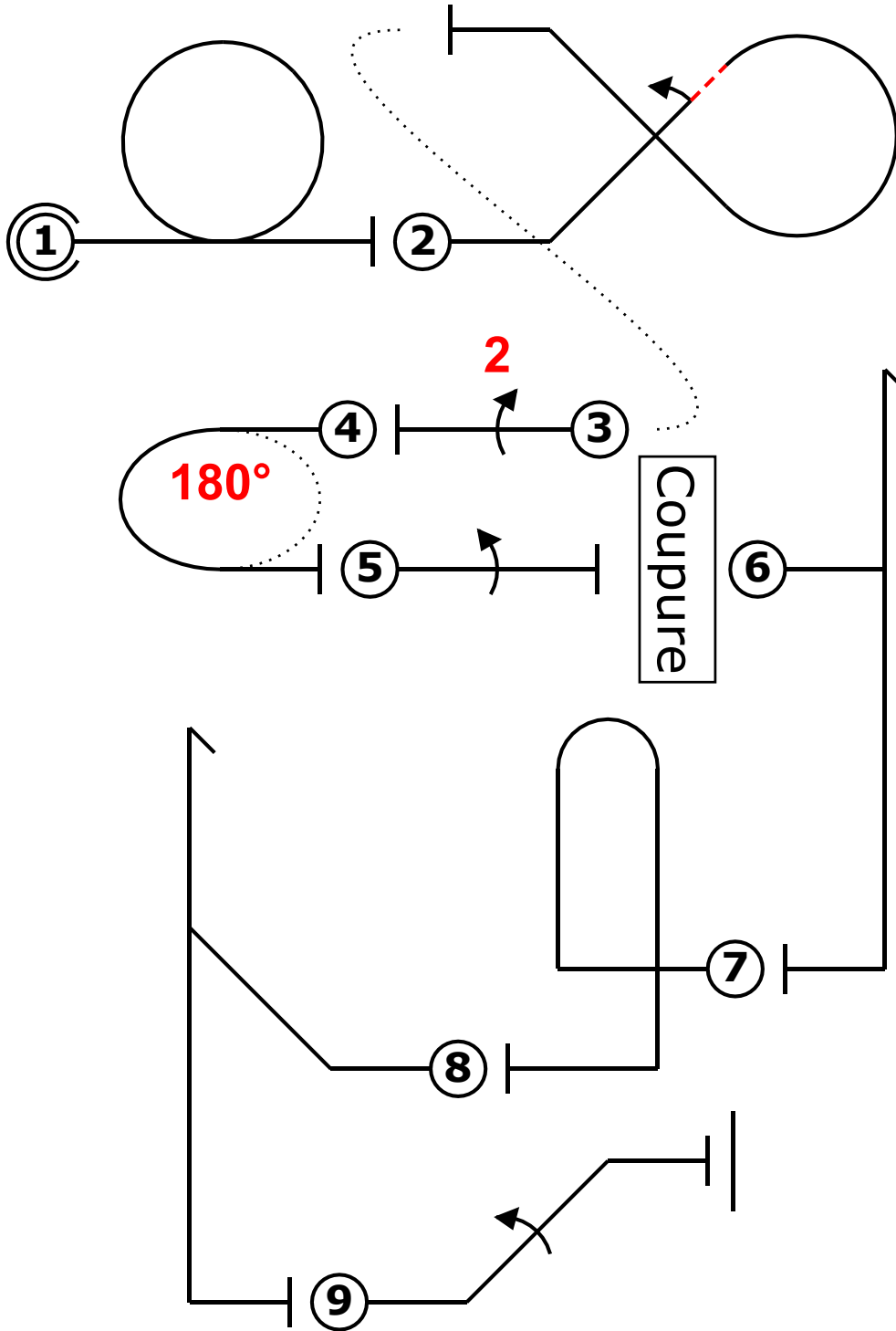

Avion			
Fig	Aresti	K	
1	7.4.1.1	10	10
2	7.3.2.1 9.1.2.2	14 6	20
3	1.1.1.1 9.2.3.4	2 9	11
4	2.2.1.1	4	4
5	1.1.1.1 9.1.3.4	2 8	10
6	5.2.1.1	17	17
7	8.4.1.1	13	13
8	5.3.1.1	18	18
9	1.1.2.1 9.1.2.4	7 10	17
Total K = 120 (max K = 120)			

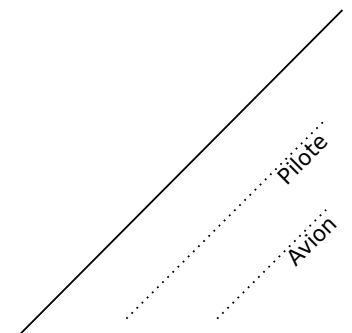

Pilote ID		Form C
France Espoirs inconnu		Vol N°

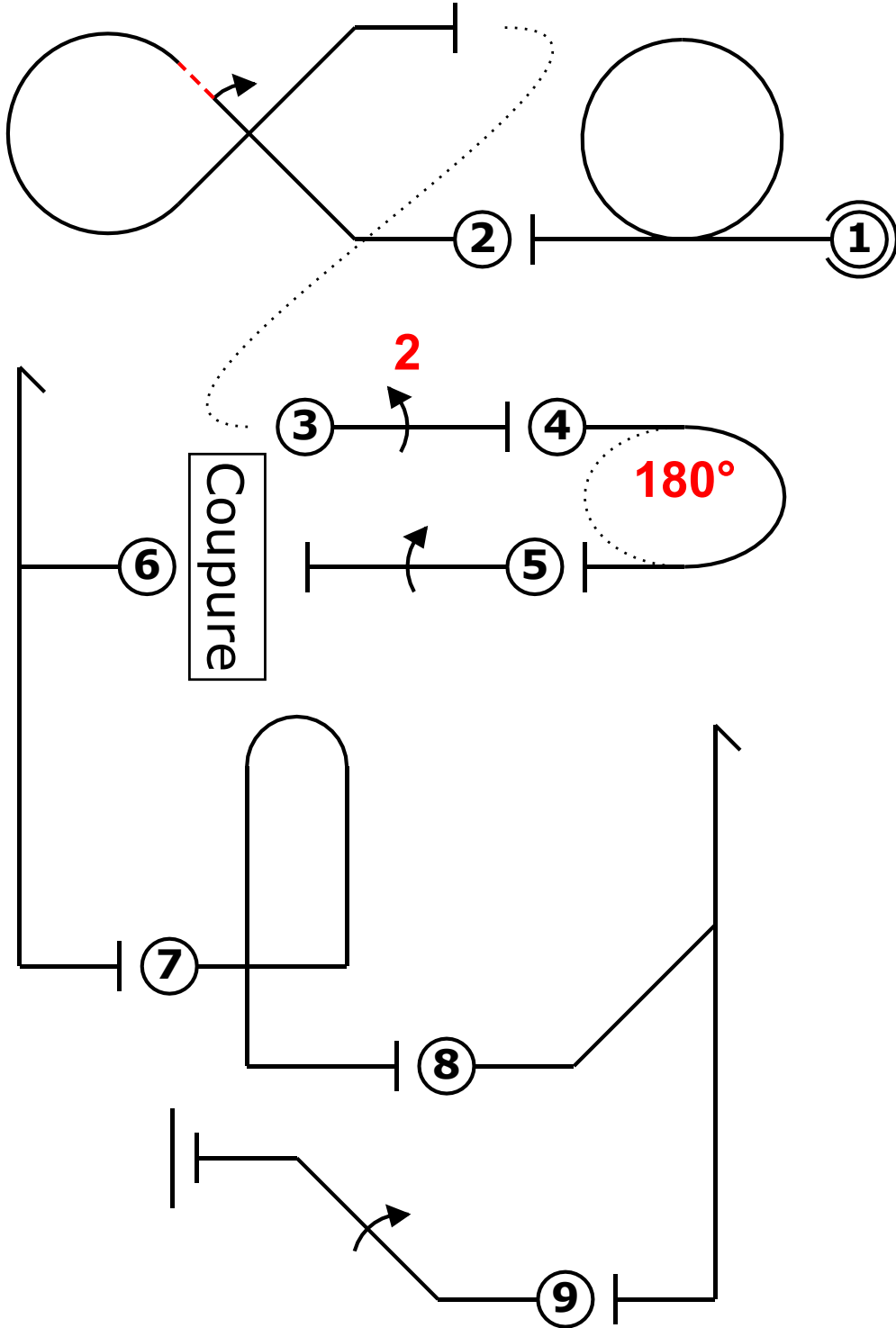

Avion			
Fig	Aresti	K	
1	7.4.1.1	10	10
2	7.3.2.1 9.1.2.2	14 6	20
3	1.1.1.1 9.2.3.4	2 9	11
4	2.2.1.1	4	4
5	1.1.1.1 9.1.3.4	2 8	10
6	5.2.1.1	17	17
7	8.4.1.1	13	13
8	5.3.1.1	18	18
9	1.1.2.1 9.1.2.4	7 10	17
Total K = 120 (max K = 120)			

